

INSTALLATION INSTRUCTIONS

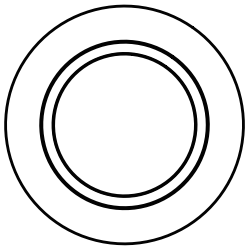

ROUND SURFACE MOUNT



LED DISK LIGHT

Provides surface mount light for new construction applications. Unit fits most 4" junction boxes and can replace 5", 6" recessed can lights to eliminate baffles and fire rated boxes. It is also suitable for use in dry, damp or wet locations.

5CCT Selectable

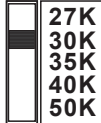

WARNING

FOR YOUR SAFETY READ AND UNDERSTAND INSTRUCTIONS COMPLETELY BEFORE STARTING INSTALLATION. BEFORE WIRING TO POWER SUPPLY, TURN OFF ELECTRICITY AT THE FUSE OR CIRCUIT BREAKER BOX.



CAUTION: RISK OF FIRE

SUPPLY CONDUCTORS (POWER WIRES) CONNECTING THE FIXTURE MUST BE RATED MINIMUM 90°C. IF UNCERTAIN, CONSULT AN ELECTRICIAN.



CAUTION: RISK OF ELECTRIC SHOCK

DISCONNECT POWER BEFORE OR CIRCUIT BREAKER BEFORE INSTALLING OR SERVICING.



SAFETY PRECAUTIONS

FOR SAFETY, READ AND UNDERSTAND INSTRUCTIONS COMPLETELY BEFORE STARTING INSTALLATION. ELECTRICITY SHOULD BE TURNED OFF AT THE FUSE OR THE CIRCUIT BREAKER BOX BEFORE INSTALLING THE FIXTURE. ALL ELECTRICAL CONNECTIONS MUST BE IN ACCORDANCE WITH N. E. C. OR YOUR LOCAL CODE.

PACKAGE CONTENTS

A

LED Disk Light



(1 pc)

B

Mounting screws



(4 pcs)

C

Wire nuts



(3 pcs)

D

Mounting plate



(1 pc)

ASSEMBLY INSTRUCTIONS

1. PREPARING FOR INSTALLATION: DISCONNECT ELECTRICAL POWER BEFORE INSTALLING OR SERVICING ANY PART OF THIS FIXTURE.
2. THIS PRODUCT SHALL BE SURFACE MOUNTED WITH JUNCTION BOX OR NON-COMBUSTIBLE SURFACE ABOVE 4 FEET (1.2 METER) HIGH. USER SHOULD PREPARE NECESSARY ACCESSORIES AND SPARE PARTS (NOT PROVIDED) INCLUDING JUNCTION BOX AND SCREWS.

INSTALLATION (CONSULT A QUALIFIED ELECTRICIAN BEFORE INSTALLING)

1. Prior to installation, install mounting plate into the electrical outlet box with mounting screws. Drive screws completely to the end of the junction box.

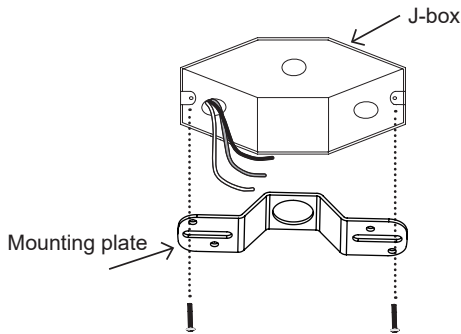

2. Connect supply wires to wires on fixture with wire nuts or push wires into Quick Connector. Connect white to white, black to black, and copper wire to copper wire as grounding connection.

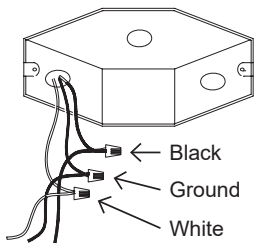

3. Completing the installation by attaching the fixture into the mounting plate tightly to the j-box. Attach the diffuser by twisting and lock the diffuser in place.

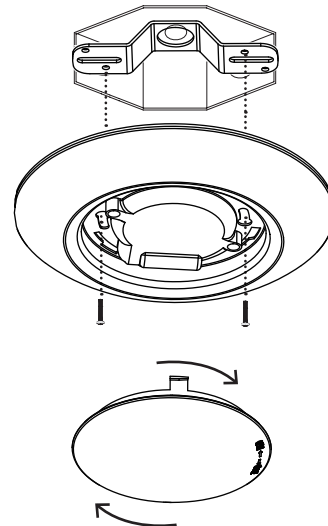

COMPATIBLE DIMMERS

LUTRON	LEVITON
• PD-6WCL	• 6681
• DVCL-153P	• 6672
• CTCL-153P	
• MACL-153M	
• TGCL-153P	
• LGCL-153P	



WARNING:

Changes or modifications not expressly approved by the party responsible for compliance could void the user's authority to operate the equipment.